



Grinder Model:

**XRV-500**  
**XRV-600**  
**XRV-700**

Common Applications:

Plastic Recycling  
Plastic Purgings  
Plastic Reclaim



# HARDWORKING AMERICAN-MADE MACHINERY

**EVER > NEW**  
TECHNOLOGY

Cresswood's exclusive Ever New Technology allows for replacement of all key wear items to bring your machine back to like-new standards.

The rugged, extreme duty XRV-500, 600 and 700 make up the family of "Dump and Go" Cresswood shredders that are a plastic recycler's best friend. In the toughest plastic applications, this class of machines thrives. These machines can size-reduce heavy purge, thick walled pipe, barrels, mixed plastics, and can get your valuable product back into your production process or processed for recycling.

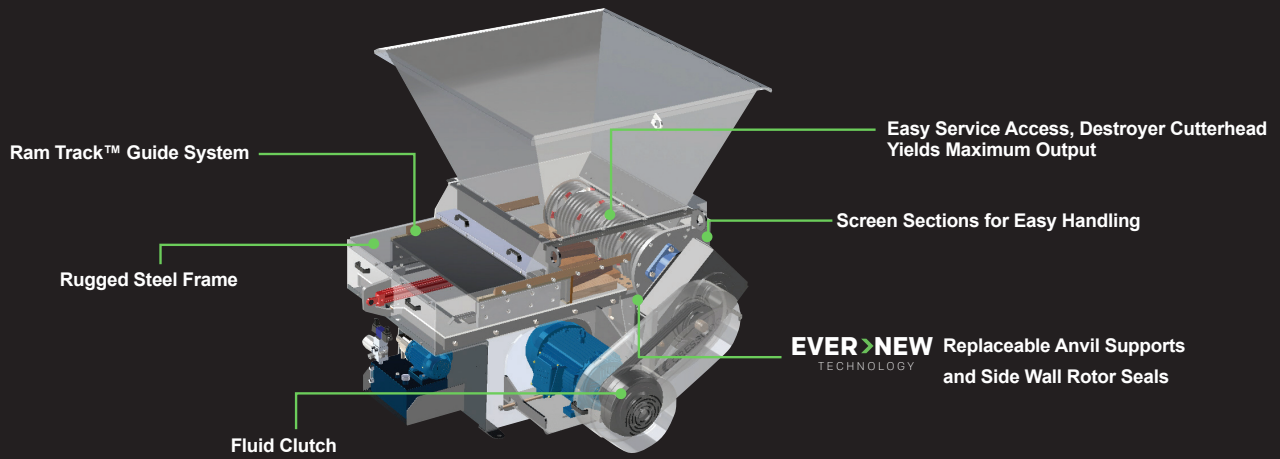

## Specifications

	<b>XRV-500</b>	<b>XRV-600</b>	<b>XRV-700</b>
Motor HP	60, 75, 100	75, 100, 125	125, 150, 200
Cutting Chamber	50" x 57"	60" x 68"	70" x 69"
Ram Stroke	40"	50"	50"
Rotor Diameter	16"	16"	20"
Grinding Head Speed	50-150 rpm	50-150 rpm	50-150 rpm
Frame Thickness	5/8"	5/8"	5/8"
Number of Cutter Teeth	70	84	98
Shaft Diameter	4"	4.5"	5"
Mid-Range Hopper Volume	3 Cubic Yards	6 Cubic Yards	7.5 Cubic Yards
Floor Area of Unit	89" x 120"	108" x 138"	130 x 143"
Shipping Weight	12,500 lbs.	15,000 lbs.	20,000 lbs.

\* Specifications are subject to change

\*\* The output of these machines can be optimized for your application by selecting different screens, amount of cutter teeth, cutter teeth placement, and rotor selection.



55 W. Lincoln Hwy • Cortland IL, 60112 • 800-962-7302 • [www.Cresswood.com](http://www.Cresswood.com)